



SCOUT ELECTRONICS BADGE LEADERS' PACK

This pack, together with the accompanying Scout resources, gives you a set of projects and supporting activities that will enable you to guide your troop through the Scout Electronics Badge.



"The five essential skills for success are concentration, discrimination, organisation, innovation and communication".
Michael Faraday.



THE SCOUT ELECTRONICS BADGE IS SPONSORED BY THE INSTITUTION OF ENGINEERING AND TECHNOLOGY (IET)

The IET is a world-class members' organisation for the engineering and technology community. It provides a wide-range of professional support services for engineers and technicians and represents the sector to opinion formers and the public.

In the UK there is a significant need for more people with the right qualifications, skills and experience to become engineers and technicians. As part of its charitable remit the IET has an education programme that seeks to encourage young people's interest in science and engineering, encourage them to study science, maths, design and technology and computing at school and then help them make informed choices about courses and careers.

The IET's Education for Schools and Colleges programme offers:

IET Faraday – www.ietfaraday.org

- A library of free video case-studies of innovative engineering and product designs and the engineers behind them with accompanying activities
- Free posters
- Guidance on how to deliver your own engineering activity days

FIRST® LEGO® League – www.firstlegoleague.co.uk

The UK and Ireland arm of this international robotics competition where teams undertake a project and build and programme robots using LEGO® Mindstorms® to overcome series of challenges based around real-world problems

Flipside magazine – flipside.theiet.org

The teen-magazine where fact is stranger than fiction

The IET also offers funding for engineering-based educational projects and supports some of the UK's best engineering-themed competitions. Many IET members are also STEM (Science, Technology, Engineering and Maths) Ambassadors - professional engineers who have been checked and trained to work with educational groups.

www.theiet.org/education

For information about careers in engineering, visit **www.tomorrowsengineers.org.uk**



The Institution of Engineering and Technology is registered as a Charity in England and Wales (no 211014) and Scotland (no SCO38698), Michael Faraday House, Six Hills Way, Stevenage, SG1 2AY, United Kingdom.



GraphicScience

These resources were
created by Graphic Science
www.graphicscience.co.uk

INTRODUCTION ^{1/4}

What's in this pack?

This pack, together with the accompanying Scout resources, gives you a set of electronics projects and supporting activities that will enable you to guide your troop through the Scout electronics badge. It is intended for all leaders whether or not you have previous experience of electronics.

The two packs are designed to work side-by-side.

The Leaders' Pack contains:

- Instructions on how to run the activities.
- An overview of each electronics project together with kit lists, hints and tips, and trouble-shooting information.

The Scout Pack contains:

- Background information that will help Scouts to develop their understanding of electronics and its impact on our lives.
- Step-by-step instructions for each electronics project (they only need to complete three of these projects to earn the badge).

The projects are graded with the simplest needing no specialist equipment and easily obtainable electronic components. In all cases, components and catalogue codes are given for at least one supplier. Some costs can be reduced by buying materials in bulk. It is also worth shopping around for batteries as prices vary considerably.

The projects are flexible and most can be achieved using more than one approach. Although producing a soldered circuit is a required element of the badge work, the majority of projects can be achieved without soldering.

The Scout Pack is available for download as a single document and in sections. This means you can either choose to print the whole pack, or only to print the sections the Scouts will be using to complete the badge.

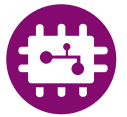

INTRODUCTION 2/4

Badge requirements

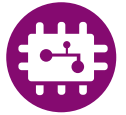

To gain this badge, Scouts must complete the requirements below:

1. Show an understanding of components by completing the following three tasks:
 - a. Be able to recognise common electronic components that are shown to you. Explain, in simple terms, the functions they perform in electronic circuits.
 - b. Understand the systems used for marking components with their values and be able to identify the values of resistors and capacitors so marked. Understand the importance of the rating of a component.
 - c. Know the symbols that are used to represent common components in circuit diagrams. Show how to identify the polarity of a diode and a specific pin number on an integrated circuit.
2. Demonstrate knowledge of safe working practices to be followed when handling electronic components, and circuit boards and when undertaking soldering.
3. Use a multimeter to measure voltage, current and resistance in a simple circuit. Discuss the relationship between these values.
4. Discuss the main differences in operation of digital and analogue circuits.
5. Construct three simple circuits, one of which should be based mainly on digital electronics. These may be from a book or magazine, or circuits that you have designed yourself. At least one of the circuits should be soldered using either strip-board or a custom made printed circuit board. Explain the principles behind the operation of each circuit and the typical values of voltage and current found in each.



"The five essential skills for success are concentration, discrimination, organisation, innovation and communication".

Michael Faraday.

INTRODUCTION 3/4

Pack contents



Section	Leaders' Pk pages	Scout Pk pages	Relevance to badge
Structuring activities	5	N/A	Preparation
Safety considerations	9	see 6 (soldering)	Preparation
Background Information and Activities - all Scouts should have these pages (1-13 of Scout Pack)			
How Does Electronics Work?	Scout pack only	3	Preparation
Circuit Basics - Series and Parallel Circuits	Scout pack only	4	Preparation
Circuit Basics - Voltage Dividers	Scout pack only	5	Preparation
Digital and Analogue	Scout pack only	5	Preparation
Soldering - Important Information	Scout pack only	6	Preparation
Activities 01 - Electronic Diary	10	7	Preparation
Activities 02 - Smart Phone Exploded	10	7	Preparation
Activities 03 - Component Recognition and Matching Game	11	8	1a, 1c
Activities 04 - Bring it Ohm!	12	9	1b
Activities 05 - How to use a Multimeter	15	10	3
Simple Projects - Scouts should complete no more than one of these			
Projects 01 - Light-up Greetings Cards	17	24	5
Projects 02 - Brush Bug	19	17	5
Projects 03 - USB-powered Colour-changing LED Light	21	19	5
Intermediate Projects - Scouts could complete one or two of these			
Projects 04 - Steady Hand Game	23	21	5
Projects 05 - Night Light	25	24	5
Projects 06 - Light-up Map	27	28	5
Advanced Projects - Scouts should complete at least one of these			
Projects 07 - Memory Reaction and Time Game	29	31	5, 4, 2
Projects 08 - Electronic Dice	31	33	5, 4, 2
Projects 09 - Guy Rope Guides	33	35	5, 4, 2
Challenges - Scouts could complete one of these in place of one of the projects above			
Challenges 01 - Make a Credit Card Torch	36	38	5 (will vary)
Challenges 02 - Make a Marshmallow Toasting Alarm	36	39	5 (will vary)
Challenges 03 - Make a flashing badge	36	40	5 (will vary)

INTRODUCTION 4/4

How to use this pack

All Scouts should be given pages 1-13 of the Scout Pack as these provide important background and safety information as well as key activities that will help them to earn their badge. The instructions to run the activities that appear in these pages can be found in the Leaders' Pack.

In addition to this, Scouts will need printed instructions for three projects to meet badge requirement 5. At least one of these needs to be a digital circuit and to involve soldering. The three advanced projects in the pack (Memory and Reaction Time Game, Electronic Dice, Guy Rope Guides) will allow Scouts to fulfil both of these requirements. Being able to explain how they work will also contribute towards meeting badge requirement 4.

The three simple projects (Light-up Greetings Cards, Brush Bug, USB powered Colour-changing LED) are provided as a gentle introduction and are particularly suitable for younger Scouts. If they are used, the other two projects should be chosen from the intermediate and advanced project lists.

The three challenge projects at the end of the pack offer Scouts the opportunity to design their own circuits. The challenges are graded in difficulty and could be used in place of one of the simple or intermediate projects for badge requirement 5. They could also meet other aspects of the badge requirements depending on how they are executed.

A separate glossary is also available for you and the Scouts to use as reference.

The Scout Pack, Leaders' Pack and supporting documents can be found on the Electronics Activity Badge page of the Scout Association website – scouts.org.uk/iet

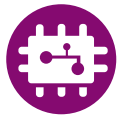

STRUCTURING ACTIVITIES 1/3

Here is an example of how you could structure the activities over a 5 - 6 week period.

Week 1: Introduction to the badge - how electronics shapes our world

Electronics has had a profound impact on our lives. So much so, that it is easy not to notice just how much electronic equipment we use. Before Scouts start to work on the practical aspects of their badge, it is worth encouraging them to reflect on this.

Activity: as in introduction and to help put electronics in context you could choose to do one or both of the following activities:

- **Electronic diary** - Scouts make a diary of everything that they use in a single weekday that uses electronics.
- **Smart phone exploded** - How were the functions of a smart phone achieved in the past? Scouts are encouraged to build a spider diagram of all the different gadgets that a smart phone can replace.

Week 2: Introduction to electronics components and first electronics project

In week 2, Scouts learn about the different electronic components and their functions (badge requirement 1) and build the first of their three circuits (badge requirement 5)

Activity: To help Scouts gain an understanding of electronic components and their functions you could do the following activity:

- **Component matching game** - Scouts work in teams to match up electronic symbols to their components.

Electronics project: For the first of three circuits that the Scouts need to build to fulfil the badge requirements you could choose one of the following easy projects:

- **Light-up greetings cards** - Scouts design and construct illuminated greeting cards using a simple circuit made from tin foil, coin battery and LEDs.
- **Brush Bug** - Scouts transform a toothbrush head in to a skittering googly eyed bug using a motor and coin battery.
- **USB colour-changing light*** - Using a USB lead Scouts can power a colour-changing LED which can then be placed inside a ping pong ball to make a glowing computer mascot.

* Projects with soldering option



"The five essential skills for success are concentration, discrimination, organisation, innovation and communication".

Michael Faraday.

STRUCTURING ACTIVITIES 2/3

Week 3: Introduction to resistance and resistor codes and second electronics project

In week 3, Scouts learn about component codes (this completes badge requirement 1) and start the second of their three electronics projects (badge requirement 5). Depending on the choice of project, there will be opportunities to use a multimeter (badge requirement 3) and do some basic soldering (badge requirement 2 and preparation for the third and final electronics project for badge requirement 5).

Activity: The following activity helps Scouts gain an understanding of the systems used for marking components:

- **Bring it Ohm! Game** - An active game for Scouts to learn about the colour-codes printed on resistors.
- **How to use a multimeter** - Scouts learn about the basic functions of a multimeter by experimenting with some simple circuits.

Electronics project: For the second of the three circuits needed to fulfil the badge requirements, Scouts could complete one of the following projects:

- **Steady hand game** - A buzzer game to test your hand eye coordination skills.
- **Night light** - Scouts construct a night light that switches on as it gets dark.
- **Light-up map*** - Scouts build an interactive map with LEDs lighting up different locations.

** Projects with soldering option*

Week 4: Completion of week 3 project, introduction to soldering

Depending on the choice of week 3 project, Scouts may require a second meeting to complete the work. Once they have completed this project, they should be given an opportunity to practice their soldering if they have not already done so.

Electronics project: If Scouts have not yet done any soldering, they could undertake the **Light-up map project**.

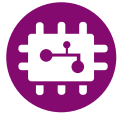

STRUCTURING ACTIVITIES 3/3

Week 5/6: Completion of the final circuit - a soldered circuit that uses digital electronics

For the final part of the badge Scouts will complete a project from a kit, or build a circuit using strip board, that includes an integrated circuit. This will need to be soldered (the final part of badge requirement 5).

Electronics project: For the last of the three circuits needed to fulfil the badge requirements, Scouts could complete one of the following digital electronics projects:

- **Reaction and memory game** - This game is built from a kit and uses resistors, LEDs and switches to test reaction times and memory.
- **Electronic dice** - This dice is built from a kit and when constructed randomly generates a number which is displayed like the face of a dice.
- **Guy rope guides** - This slightly more challenging project uses strip board and individual components to make a flashing LED that can be attached to guy ropes.

Once they have completed the project, they should explain how it works in order to fulfil badge requirement 4. There is information in the Scout pack to help them do this.

Week 5/6: (Continued)

Scouts may also enjoy thinking about and designing their own electronics projects and there are some challenges outlined in this pack if they are particularly interested.

Electronics project: These open ended challenges give Scouts the opportunity to make their own:

- **Credit card torch** - A super bright LED and a coin battery can be sandwiched together to create a handy pocket sized torch.
- **Marshmallow toasting alarm** - A buzzer that sounds if someone toasting marshmallows falls asleep preventing them from dropping the toasting fork into the fire.
- **Flashing badge** - Make an electronics badge flash by using an integrated circuit chip.

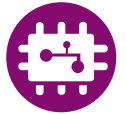

SAFETY CONSIDERATIONS

- All of the projects use batteries and therefore operate on a low voltage, however, you should remind Scouts not to experiment with mains electricity - this is at 230V and is dangerous.
- Components may heat up if wired incorrectly. Scouts should disconnect batteries when not using their electronic projects.
- Wire cutters, craft knives and soldering irons are used for certain projects. Safe working practices such as tidy work spaces in a calm and well lit, well ventilated working environment should be adhered to at all times.
- Before undertaking any soldering, Scouts should read the soldering instructions and demonstrate that they understand how to solder safely.
- Helping hands may be needed for some soldering tasks so that Scouts' fingers are kept well away from components and the tip of the soldering iron.
- Soldering irons should always be used with a circuit breaker.
- The mains cables on soldering irons need to be checked before use. Soldering irons with damaged cables should not be used.
- Mains-connected soldering irons should be the type with silicone-coated, heat-resistant cables.
- Scouts should be supervised when soldering.
- Solder may contain lead or other unpleasant chemicals, and Scouts should wash their hands after handling it.
- Safety glasses are recommended when assembling circuits. Solder can spit and trimming wires can result in bits of wire flying away from the board.
- Some of the components such as the integrated circuit chips have sharp points. Care should be taken when removing IC chips from holders.



ACTIVITIES

These games and activities help put electronics in context, introduce concepts and projects, and help meet badge requirements.

ACTIVITIES 01 - ELECTRONIC DIARY

Time needed: 20 minutes

Scouts should make a diary of everything that they use in a single weekday that uses electronics. They can do this either by reflecting together on the past day, or in advance by making a note of everything they use throughout the day.

Although the exercise prompts the Scouts to think about this as broadly as they can, you could follow this up with a discussion as it is likely there are many everyday items they will not have considered – for example low energy light bulbs, the controller on the central heating, LED bike lights, radios etc.

ACTIVITIES 02 - SMART PHONE EXPLODED

Time needed: 30 minutes

How were the functions of a smart phone achieved in the past? Scouts are encouraged to build a spider diagram of all the different gadgets that a smart phone can replace, and to think about the history of all of these items and how they have developed and changed since they were first invented.

Preparation

Each patrol will need:

- A picture of a smart phone
- String
- Sticky tape
- Paper and marker pens

You can help the Scouts to think about the history of the devices they take for granted by talking discussing your own memories and encouraging them to think about the changes that have taken place in their own and their siblings' lifetimes.

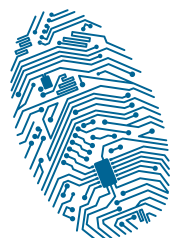

"The five essential skills for success are concentration, discrimination, organisation, innovation and communication".

Michael Faraday.

ACTIVITIES 03 - COMPONENT RECOGNITION AND MATCHING GAME



Time needed: 20 minutes

Relevant badge requirements: 1a, 1c

This game is intended to help Scouts to familiarise themselves with a range of electronic components, their circuit symbols and their functions using the component flash cards that can be downloaded from the Scout Association website – scouts.org.uk/iet.

Aim of the game:

- For Scouts to familiarise themselves with the appearance, circuit symbol and description of basic electronic components.

You will need:

- A set of the flash cards for each team. These should be pre-cut into a set of cards showing component symbols, a set showing component photographs and a set of descriptions. The cards can be downloaded via the Scout Electronics Activity Badge page of the Scout Association website – scouts.org.uk/iet.

Scouts work as teams either in pairs, small groups or patrols. Teams have to match together the photograph of the component, its circuit symbol and its description. The first team to correctly match all the cards wins. The game can be made easier by keeping the component symbols and photographs together as single cards so that teams have to match the description to one picture only. It can also be split into two rounds with photographs being matched to descriptions first and the symbols matched in a second round.

Before you play:

Most of the Scouts will have learnt about electricity at school. Spend a few minutes helping them to remember what they have learnt.

Key ideas they need to remember are:

- **Electricity carries energy.**
- **Electricity flows round circuits moving from the positive terminal to the negative terminal.***
- **Electricity takes the easiest route around a circuit.**
- **Resistance is a measure of how hard it is for electricity to travel round a circuit.**
- **A material that electricity can flow through is called a conductor.**
- **A material that electricity does not flow through is called an insulator.**

You should also make sure they understand what is meant by the term “component”.

Some of them should be able to name electronic components such as LEDs, buzzers and resistors.

*It was originally thought that electricity was carried by a flow of positively charged particles, so a system showing electricity travelling from negative to positive was developed. This convention stuck, even after it was discovered that electricity was actually carried by negatively charged electrons so is really flowing in the opposite direction.

ACTIVITIES 04 - BRING IT OHM! 1/3

Time needed: 30 minutes

Relevant badge requirement: 1b

Introduction

Resistors are essential components in most electronics circuits. They are tiny and it would be impossible to print much information on them, so instead a labelling system has been developed using coloured bands.

Most resistors are labelled with four coloured bands. At one end will be a gold or silver band – this represents the tolerance of the resistor (gold = 5% and silver = 10%). This band is not important in most circuits and will be ignored for the purpose of this game.

Looking at the resistor with the tolerance band on the right, the other three bands represent the resistance value of the resistor.



Resistor colour codes

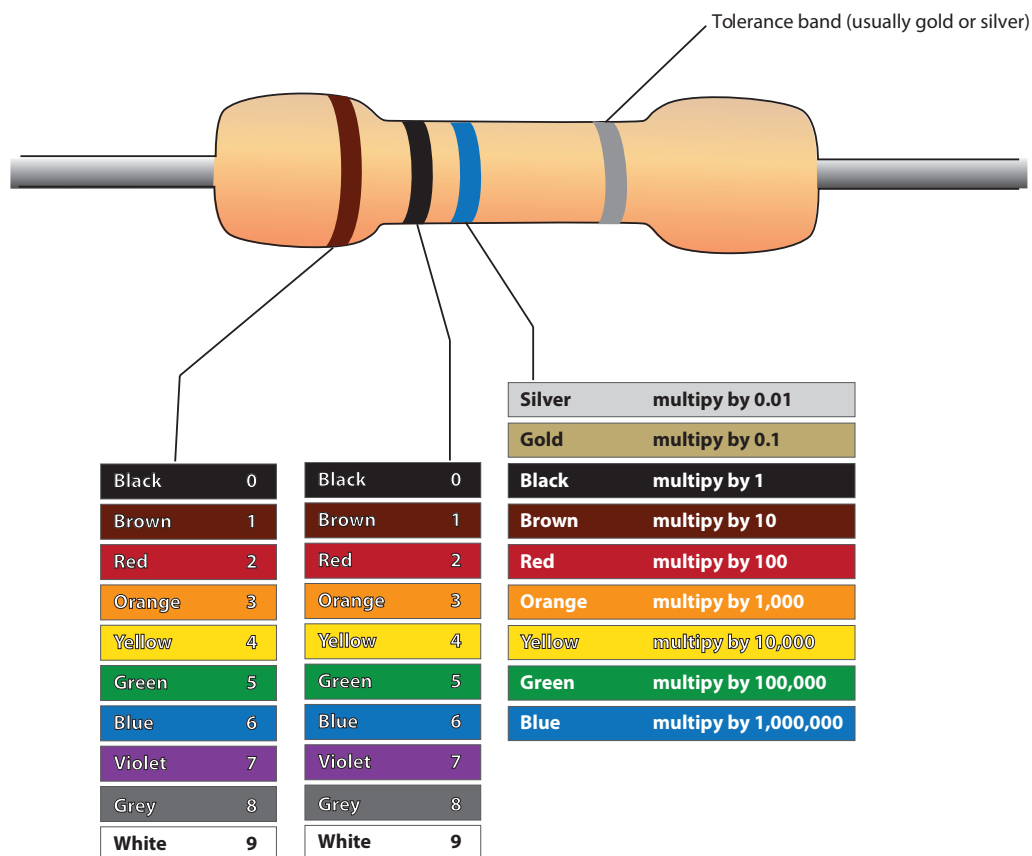

ACTIVITIES 04 - BRING IT OHM! 2/3

- The first band (left-most) represents the first digit of the resistor value.
- The second band represents the second digit of the resistor value.
- The third band is the multiplier of this value.

For example for a 47Ω resistor, the first band will be yellow (4), the second band will be violet (7) and the third band will be black (x1). A 470Ω resistor would be represented by yellow(4), violet(7), brown (x10). A 4.7Ω resistor by yellow (4), violet(7), gold (x0.1) and so on...

How to play

You will need:

- One resistor colour code explanation sheet per team (see Scout pack).
- A set of coloured strips representing the code, cut up and ready to use for each team (available via the Electronics Activity Badge page of the Scout Association website – scouts.org.uk/iet).
- A hall or clear space to run around in.
- A winner's prize.

Instructions

Players are divided into teams and each is given a crib sheet explaining resistor values and a set of coloured stripes representing the coloured bands on the resistor.

Teams stand at one end of the room, and the leader stands at the other.

First, the leader explains to everyone how the numbering system works. At this stage, it might be worth testing everyone with an easy number to make sure they have understood.

Once the rules are clear, the leader calls out numbers for resistor ohm values and the teams have to assemble the correct combination of strips and run across the room to present them to the leader in the right order. Points are awarded for the first team to reach the leader with the correct combination.

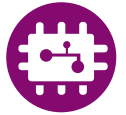

ACTIVITIES 04 - BRING IT OHM! 3/3

Here are some values to get started:

Value	Band 1	Band 2	Band 3
22 Ω	Red	Red	Black
1000 Ω	Brown	Black	Red
10,000 Ω	Brown	Black	Orange
470 Ω	Yellow	Violet	Brown
220 Ω	Red	Red	Brown
56 Ω	Green	Blue	Black
1 Ω	Brown	Black	Gold
3300 Ω	Orange	Orange	Red
560 Ω	Green	Blue	Brown
220,000 Ω	Red	Red	Yellow
1000,000 Ω	Brown	Black	Green
2,200 Ω	Red	Red	Red
47 Ω	Yellow	Violet	Black
22,000 Ω	Red	Red	Orange
47000 Ω	Yellow	Violet	Orange
560 Ω	Green	Blue	Brown
100,000 Ω	Brown	Black	Yellow
2.2 Ω	Red	Red	Gold
0.1 Ω	Brown	Black	Silver
4.7 Ω	Yellow	Violet	Gold



ACTIVITIES 05 -

HOW TO USE A MULTIMETER 1/2

Time needed: 30 minutes

Relevant badge requirement: 3

This activity guides Scouts through how to use a multimeter to measure voltage, resistance and current. Scouts can also refer to the How does Electronics Work? section of their packs to help them understand the basic concepts. The Scout Pack contains instructions on how to use a typical multimeter, but you should also refer to the instruction manual for the multimeter you are using if possible.

A variety of components can be used for this activity. These can be borrowed from other projects since they can all be re-used. The only important factors to bear in mind is that when using a 9V battery, any resistors used should be at least 100Ω and that an appropriate current limiting resistor (at least 330Ω) must be used for any circuits containing an LED.

Preparation - you will need:

- A multimeter
- Terminal block
- A battery clip
- 9V battery (these can be shared between groups)
- 330Ω resistor (a 470Ω resistor can be used as an alternative)
- Additional resistors of different values - must be 100Ω or above
- LEDs
- Light Dependent Resistors or other variable resistors (optional)
- Wire
- Screwdrivers

Introducing the activity:

Multimeters can be damaged easily, so before Scouts start using one, you should explain how the multimeter they will be using works and make sure they familiarise themselves with the different settings.

A diagram of a standard multimeter is included in the Scout pack.

You will also need to remind them about current, voltage and resistance.

Make sure they follow these rules when using the multimeter:

- Always disconnect the multimeter before changing any settings
- Always check the settings before you connect to a circuit
- Never leave a multimeter set to a current range

Once the Scouts are familiar with the basics they can test some simple circuits using the multimeter. Some examples are given in the Scout pack. These can be modified using different values of resistors to encourage the Scouts to investigate for themselves.

It is important that you check the circuits containing LEDs before they attach the battery. LEDs will explode if they receive too much current or too high a voltage.



ACTIVITIES 05 - HOW TO USE A MULTIMETER 2/2

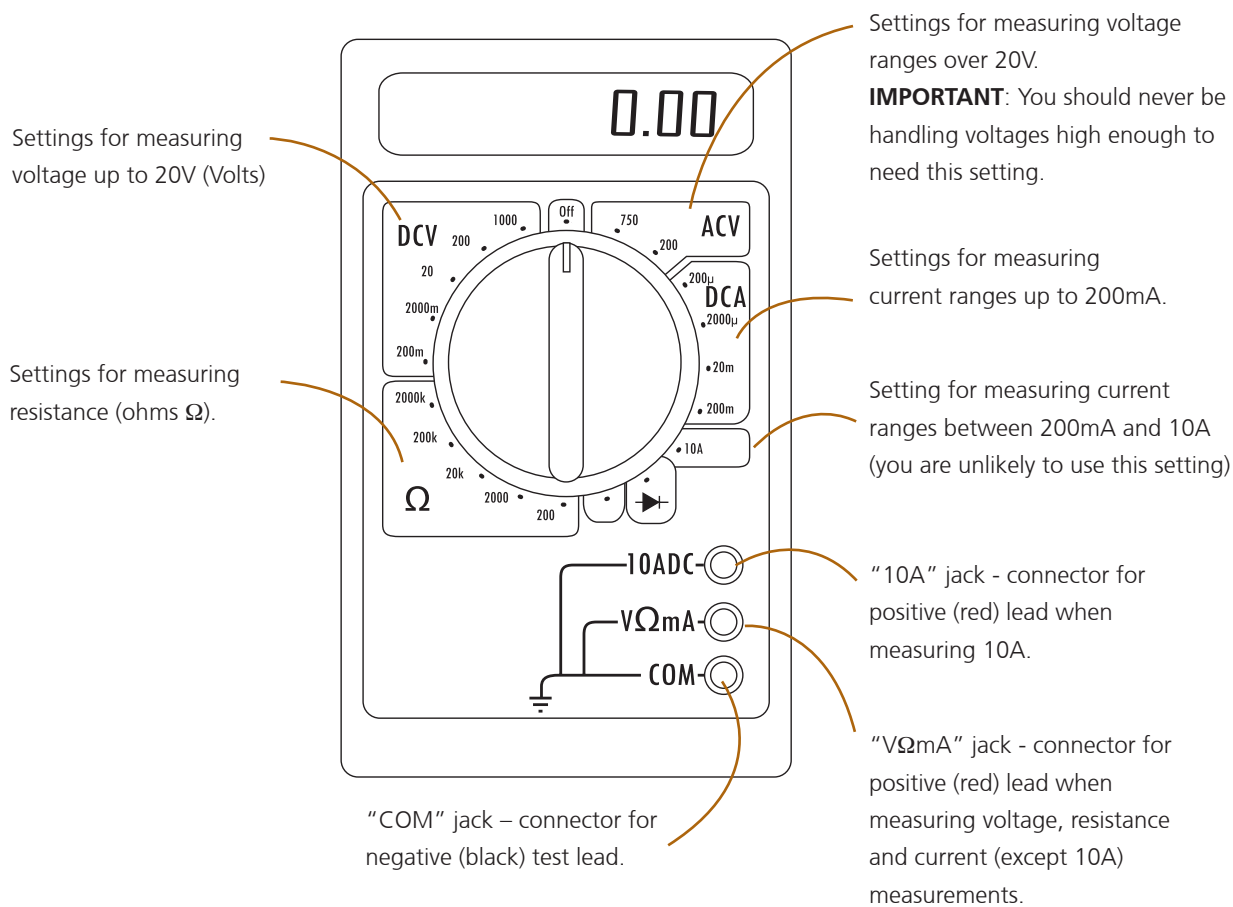

Look after your multimeter – they can get damaged easily

- Always disconnect the multimeter before changing any settings.
- Always check the settings before you connect to a circuit.
- Never leave a multimeter set to a current range.

PROJECTS 01 - LIGHT-UP GREETINGS CARDS 1/2

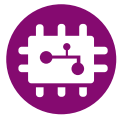

Difficulty rating: Easy

Time needed: 30 minutes - 1 hour

Light-up greeting cards use a simple circuit with a small coin battery to light up one or more LEDs that form part of a greeting card design. The project offers Scouts the opportunity to investigate the basics of an LED circuit, build a simple circuit and work out for themselves how to add features such as switches and additional LEDs.

A template for the cards, including a circuit diagram, is provided in the downloadable resources, but they can also design what they want from scratch. Using tin foil is the cheapest and most accessible way to make these cards and the instructions in the Scout pack focus on this approach. However, they can also be made using conductive tape, or Bare Conductive Paint.

Preparation

Electronic parts	Kitronik code	Rapid Electronics code	Indicative cost (2012)
LEDs - mixture of colours	3504 (red)	56-0430 (yellow)	6p
	3505 (green)	56-0435 (green)	
	3506 (red)	56-0440 (yellow)	
3V coin batteries with PCB mount if possible (e.g. CR1220)	4807	18-0467	75p

Other consumables

Tin foil

Double-sided tape or carpet tape

Strong sticky tape

Printouts of the template on to thin card

Clean card suitable for making greetings cards

Tools and equipment

Scissors

Hole punch

PROJECTS 01 - LIGHT-UP GREETINGS CARDS 2/2

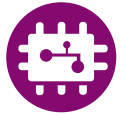

- In theory, connecting a 3V battery and an LED without a current limiting resistor should destroy the LED. However most standard LEDs can withstand higher currents and voltages than their published operating values. Coin cells can only sustain a limited amount of output power and under load the current drops, so after a short period the LED will be operating within its specified limits anyway.
- Backing the foil onto double-sided tape makes it stronger and easier to work with. The sturdiness of carpet tape means it works particularly well.

Trouble-shooting:

- Any splits in the tin foil will break the circuit. They can be patched with a small bit of foil, but it is difficult to make a reliable connection and it might be better to start again.
- LEDs and batteries need to be fixed firmly in place to make a good connection.
- A 3V battery will only power more than one LED if the LEDs are connected in parallel. It will not power more than one LED in a series circuit.
- LEDs must be the right way round relative to the battery to work.

Meeting the aims of the badge:

- Develops understanding that electricity flows around a circuit from the positive to the negative terminal.
- Introduces the idea that electronic components have an operating voltage and current.
- Introduces diodes - the LED is a type of diode. Diodes can only let electricity pass in one direction.

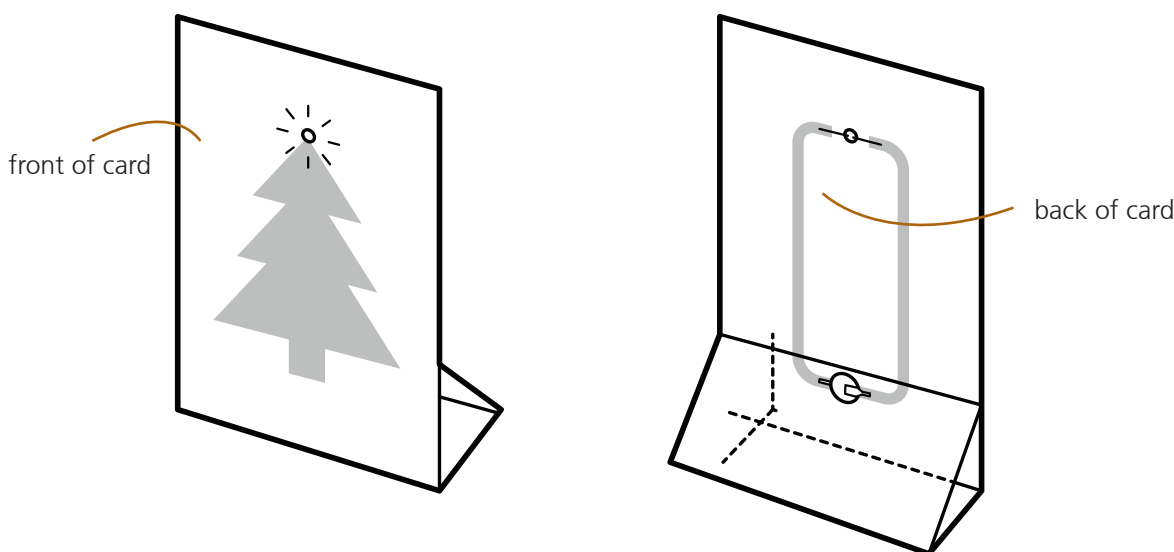

PROJECTS 02 - BRUSH BUG 1/2

Difficulty rating: Easy

Time needed: 30 minutes

This simple project connects a miniature mobile phone vibration motor powered by a 3V coin battery to the top of a toothbrush head. The vibration sends the brush head skittering all over the place. Larger versions can be made using a larger brush such as a nail brush, AA batteries and a larger motor. For larger models, a vibration motor can be created by adding an offset weight to a basic motor. The project benefits from the addition of googly eyes.

Preparation

For each bug, you will need:



Electronic parts	Kitronik code	Rapid Electronics code	Indicative cost (2012)
One CR2016 3V battery	2264	18-5097	28p
One 3V mini vibration motor	2541	-	£1.75

Other consumables

A toothbrush (a wider-headed brush will be better than a narrower one)	15p
2 paper clips	
Foam tape or hot glue	
Pipe cleaners and googly eyes for decoration	
Insulation or other tape	

Tools and equipment

Scissors

PROJECTS 02 - BRUSH BUG 2/2

- You may need to help Scouts cut off the head of the toothbrushes. The easiest way to do this is by twisting the head from the brush.

Trouble-shooting:

- The motor's wires are quite fine, which means that greater care needs to be taken when stripping the insulation to avoid breaking through the wire.
- The motor's axle must be able to rotate freely.
- The weight of the battery and motor on the brush head can make it unstable. If this is a problem, the bug can be stabilised using pipe cleaners.

Meeting the aims of the badge:

- Develops the understanding that electricity flows around a circuit from the positive to the negative terminal.
 - Establishes the idea that electronic components have an operating voltage and current.
-

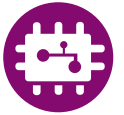
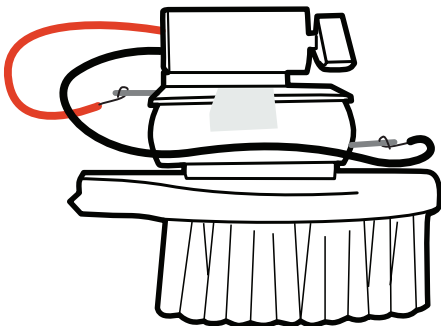

PROJECTS 03 - USB-POWERED COLOUR-CHANGING LED 1/2



Difficulty rating: Easy

Time needed: 30 minutes



This simple project demonstrates the use of a USB cable as a power source for an LED light. The colour-changing LED requires 5V, which is the same voltage as the USB cable delivers, so no additional resistance is needed for this circuit. If alternative LEDs are used, appropriate resistors will need to be added to the circuit as different coloured LEDs require different voltages.



The LED can be taped to the wire, or the two can be soldered together. Once they have put together the colour-changing LED, the Scouts can use it to light up a ping-pong ball with a hole cut in it. They could then draw an image on the outside of the ball, or add eyes whiskers and paper ears to make it in to a computer mouse.



Preparation:

Electronic parts	Kitronik code	Rapid code	Indicative cost (2012)
USB power cable	4101	-	71p
10mm 5V Colour-changing LED	3544	55-0780	66p

Other consumables

Insulating tape

Soldering equipment (optional)

Ping pong ball (optional)

Pens, paper and tape (optional)

Tools and equipment

Computer or USB power adapter for testing

PROJECTS 03 - USB-POWERED COLOUR-CHANGING LED 2/2

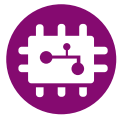

- The Kitronik USB cables contain a positive and a negative wire only. Other USB cables are likely to contain four wires. Only the negative (black) and positive (red) wires are used in this project, any other wires should be ignored.
- USB cables that have a connector at both ends should be prepared by cutting off the connector on the opposite end to the standard USB plug.
- This is a good project for introducing soldering. The soldering is fairly straight-forward and mistakes can be corrected relatively easily and inexpensively.
- USB devices such as this can only draw up to 100mA from a computer. Devices that need more than this have to gain permission from the host computer through a process called negotiation.

Advice on soldering:

- Give Scouts only as much solder as they need for the project. The temptation to see what happens when a soldering iron is held against a whole reel of solder can be hard to resist!
- Lead-free solder can leave a residue on the tip of the soldering iron that stops it from working properly. This should be cleaned using a soldering iron tip cleaner.
Never clean soldering irons with an abrasive as this will remove their coating.

Trouble-shooting:

- The LED must be wired the correct way round to work.
- Short circuits can be caused by the two LED terminals making contact or bare wire from the USB cable making contact. This can be avoided by covering any exposed wire with insulating tape.
- For USB cables with more than two wires, make sure only the red and black power wires are used.

Meeting the aims of the badge:

- Demonstrates that power can be drawn from different sources.
 - Re-iterates learning about LEDs being polar and needing to be wired correctly to work.
 - Basic soldering (optional).
-

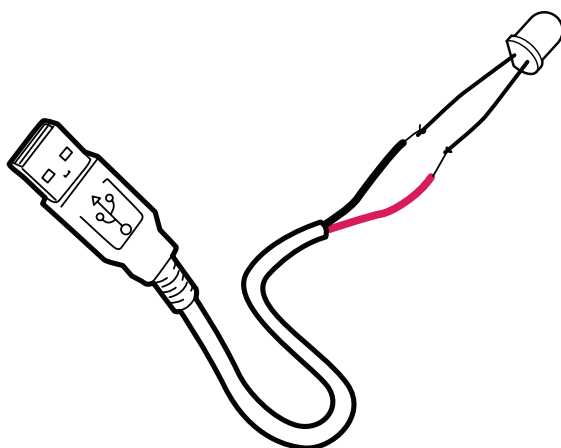

PROJECTS 04 - STEADY HAND GAME 1/2



Time needed: 1 – 2hrs

Difficulty rating: Intermediate

A version of the classic game where the player has to guide a loop around a wire without the loop touching the wire. If the loop and wire touch, a buzzer sounds. The buzzer noise is sustained briefly through the addition of an electrolytic capacitor.

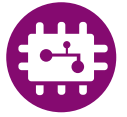

This project can be completed individually, or working in patrols or small groups.

Preparation:

Electronic parts	Kitronik code	Rapid Electronics code	Indicative cost (2012)
9V PP3 Battery	2211-10	18-4794	50p
PP3 Battery clip lead	2257-25	18-0092	7p
9V Piezo buzzer with drive	3301	35-0115	76p
470 μ F, 16V Electrolytic capacitor	3102-470u	11-0025	5p
4-Pole terminal block connector	2410	21-0100	10p
50cm Bare copper wire or other bare wire (e.g. florists wire)	2412	05-0300	£10/roll
70cm Stranded insulated wire	2410	01-0400	£5/roll

Other consumables

Foam tape (optional)

Tools and equipment

Wire strippers

Wire cutters

Screwdriver

PROJECTS 04 - STEADY HAND GAME 2/2

- Terminal block is generally supplied in 12-pole lengths which can easily be split into the desired amounts.
- Stranded wire is recommended to make the loop because the multiple strands make it more resistant to breakage. However, non-stranded wire can be used as an alternative.
- Foam tape is the easiest way of attaching the buzzer and blocks to the box.
- If running this project with a group of Scouts at the same time, it is preferable to be able to supply one screwdriver per group as each group is likely to reach the point where they need to fix the wires into the terminal block at around the same time.

Trouble-shooting:

- The buzzer and the capacitor need to be connected the same way round, and in the correct orientation to the battery for the circuit to work correctly.

Meeting the aims of the badge:

- Introduces capacitance – the charge stored in the capacitor is used to sustain the buzzer for a few moments after contact between the loop and the wire is broken.
-

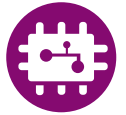
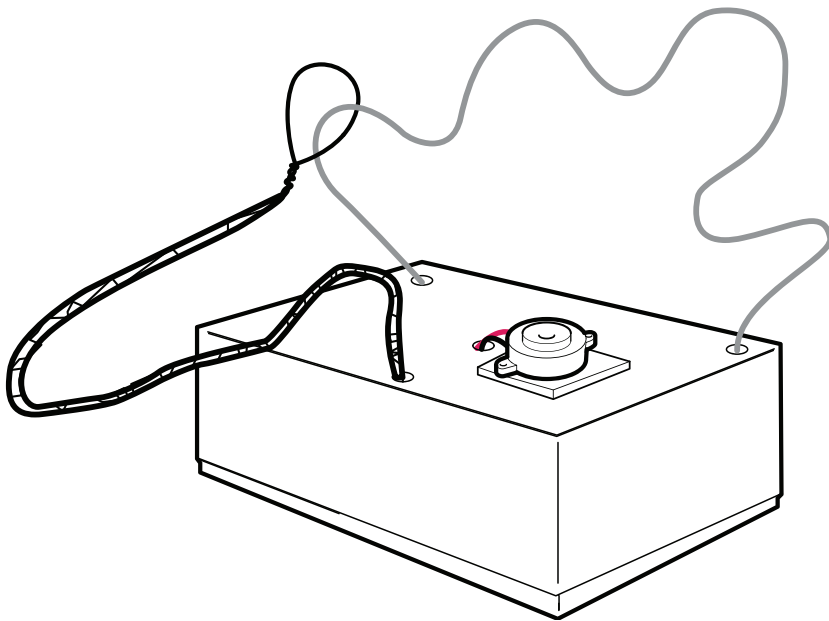

PROJECTS 05 - NIGHT LIGHT 1/2



Difficulty: Intermediate

Time needed: 1 -2 hrs

This project uses a light dependent resistor (LDR) to build an LED light that switches on when it gets dark. The circuit for this night light is made using Bare Conductive paint on thin card. The LDR and resistor create a variable voltage divider which switches on a transistor to control two bright LEDs. The Scouts resources to accompany this project include a circuit diagram to help illustrate this. The circuit is contained in a plastic pint bottle with the LDR fitted into the lid.

Preparation:

Electronic parts	Kitronik code	Indicative cost (2012)
9V PP3 battery	2211-10	55p
PP3 battery clip lead	2257-25	8p
1x Miniature LDR (resistance: daylight 5k, dark 20M)	3514	24p
2x Ultrabright LEDs	3524-01	60p
1x 100K Resistor	3003-100k	1p
1x BC547 Transistor	2901	4p
Bare Conductive Paint	4801 (50ml pot) - £18 4804 (10ml pen) - £6 Can also be bought direct from www.bareconductive.com	

Other consumables

Circuit copied onto thin card

Clean, dry 1 pint PET milk bottle with lid

Masking tape or other removable tape

Duct tape (optional)

Tools and equipment

Paint brushes

Scissors

Single-hole punch or craft knife

PROJECTS 05 - NIGHT LIGHT 2/2

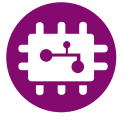

Hints and trouble-shooting:

- The neck of a PET milk bottle is just large enough to fit a 9V PP3 battery. If trying this with a different type of bottle, check the battery will fit first.
- The circuit may need to be adjusted slightly to fit into different shaped bottles
- Although the circuit will work if painted onto paper, the components are held in place much more easily on light card.
- The connectors for the transistors break quite easily, so it is sensible to have some spares. Scouts should be encouraged to bend them into shape just once and then leave them alone to avoid breakages.
- If the connection between the LDR and the rest of the circuit is broken, the lights will stay on permanently.
- Keeping the wires on the battery clip long makes it much easier to fit into the bottle.
- The paint needs to be completely dry before the circuit will work.
- The card should be rolled (not folded) so that the circuit faces inwards. If the circuit faces outwards, or the card is folded, the paint can crack and break the circuit.
- Any cracks can be fixed with more paint, but this will also need to dry before the circuit will work.
- Scouts may need to be supervised when making a hole in the lid of the bottle.

Meeting the aims of the badge:

- Introduces the concept of resistance, transistors and a voltage divider to create a type of switch.
- Introduces the LDR - a component that uses changes in light to vary resistance.

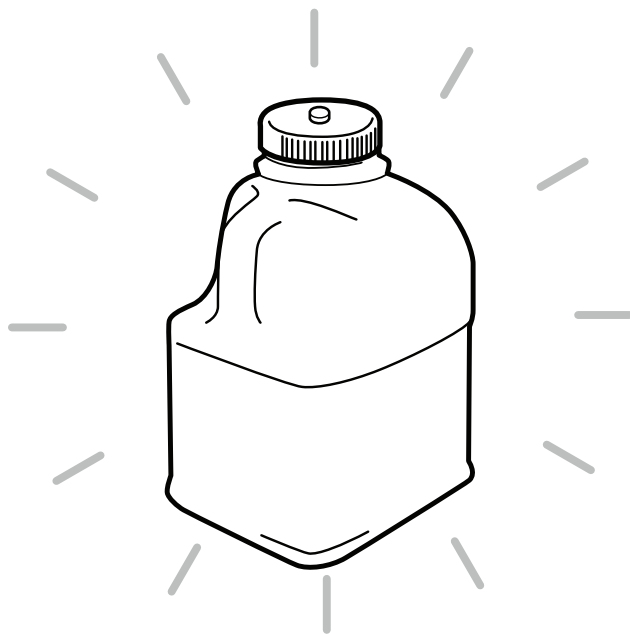

PROJECTS 06 - LIGHT-UP MAP 1/2



Time needed: 1-2 meetings

Difficulty: Intermediate

This project to build a map with specific locations marked by LEDs has a simple starting point, but can be developed into something more complicated. The map has LEDs that light up when you press a button to show you the location on the map and can be made using a combination of tape and terminal block, or soldered together.

It encourages problem solving and offers the opportunity for Scouts to practice some very basic soldering.

This project also lends itself particularly well to testing current since it is easy to break the circuit in order to connect the multimeter.



Preparation:

Electronic parts	Kitronik code	Rapid Electronics code	Indicative cost (2012)
9V PP3 battery	2211-10	18-3370	50p
PP3 battery clip lead	2257-25	18-3786	10p
5mm LEDs	3504	55-0117	7p each
Wire	2414	01-0300	£6.50/100metres
Terminal block	2410	21-0100	30p/12-terminal strip
330Ω resistors	3003-330R	62-7916	2p each

Other consumables

A pre-printed map or pens and paper to make one

Thin card (e.g. cereal box)

Paper clips

Split pins

Insulation tape

Tools and equipment

Scissors

Screwdriver

Wire cutter

Wire stripper

Soldering iron and solder (optional)

Cardboard to make a box (optional)

PROJECTS 06 - LIGHT-UP MAP 2/2

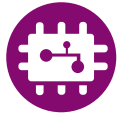

Advice on soldering:

- Give Scouts only as much solder as they need for the project. The temptation to see what happens when a soldering iron is held against a whole reel of solder can be hard to resist!
- Lead-free solder can leave a residue on the tip of the soldering iron that stops it from working properly. This should be cleaned using a soldering iron tip cleaner.
Never clean soldering irons with an abrasive as this will remove their coating.

Trouble-shooting:

- The circuit should be tested as it is built.
- LEDs must be connected the right way round.
- Check for loose connections, especially if the circuit is not being soldered.

Meeting the aims of the badge:

- Opportunity for basic soldering - this project offers plenty of opportunities to practice where mistakes can easily be corrected and will not ruin the whole project.
- Reinforces understanding of resistance and gives opportunity to calculate resistance using Ohm's law.
- Reinforces understanding of parallel circuits.
- Provides an opportunity to use a multimeter.

The project also helps to develop problem solving skills.

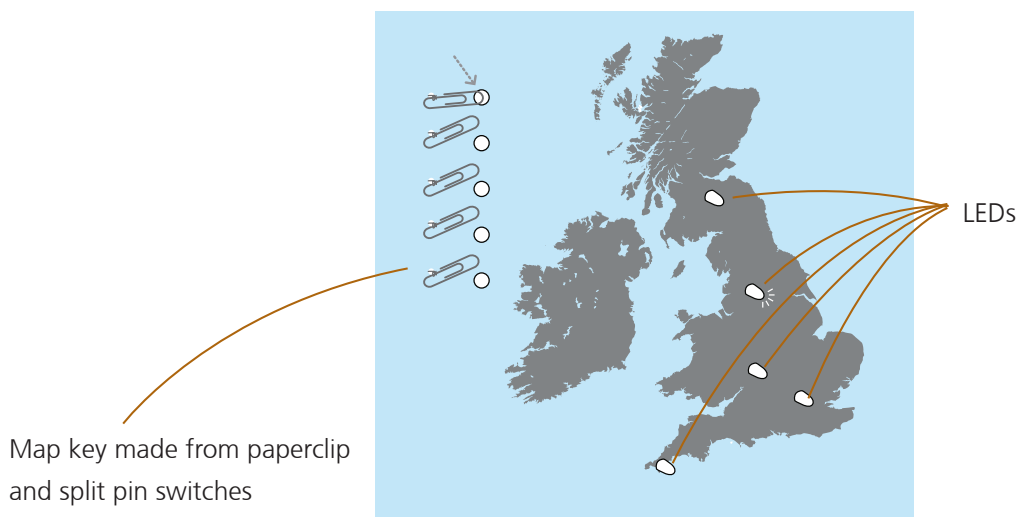

PROJECTS 07 - MEMORY REACTION AND TIME GAME 1/2

Difficulty: Intermediate

Time needed: 1 - 2hrs (1hr to build the circuit and 1hr to design a cover for the game)

This project uses a kit that can be assembled to create an electronic game. The game has two modes. The first is a memory game where the player copies a sequence of flashing lights. The second is a reaction game where the player responds to one of four LEDs that randomly light up.

The project uses a printed circuit board and pre-programmed microcontroller on an integrated circuit (IC). The microcontroller is in effect a small computer and produces digital outputs to switch LEDs on and off.

The Scouts will need to solder the circuit to ensure that the connections are secure. If any of the components come loose then the circuit will be broken and the game will not work.

Once they have built the circuit, they can design a cover with holes for the switches and LEDs, but enclosing all of the other components. This is a nice way to personalise their games as they could design the cover in any way they like.

The Scouts will have to ensure that LEDs and switches line up with the cover they design so they will need to carefully measure the spacing of the holes. The notes that accompany the kit include a technical drawing of the game dimensions to help them plan this.

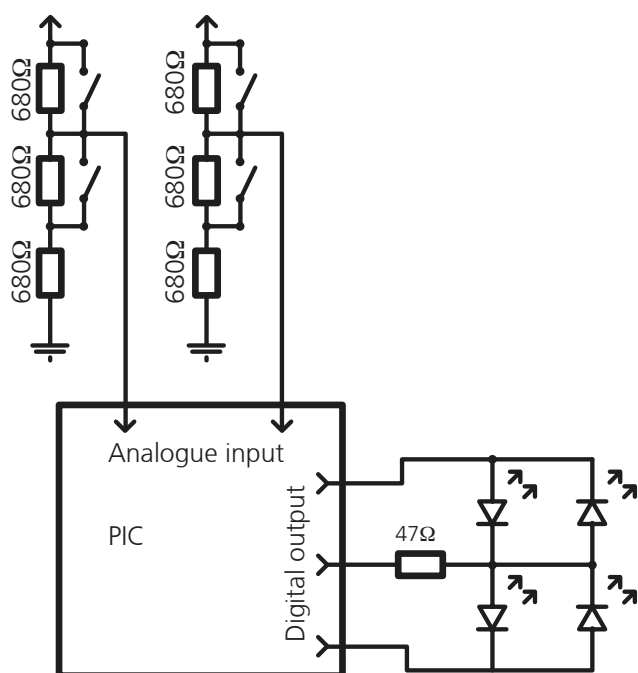

PROJECTS 07 - MEMORY REACTION AND TIME GAME 2/2

Preparation:

Electronic parts	Kitronik code	Indicative cost (2012)
1x Game Project Kit	2103	£4.50
1x AA battery pack of two	2201-01	55p

Other consumables

Solder

Card or thin foam board (optional)

Pens, pencils or crayons (optional)

Tools and equipment

Soldering iron

Wire cutters

Scissors (optional)

Single hole punch or craft knife (optional)

Modelling clay (optional)

Hints and trouble-shooting

- The kit comes with full instructions and trouble-shooting advice.
- The kit can be quite fiddly to put together as the parts are small. Scouts will need good lighting and clear work spaces.
- Some of the components will need to be trimmed with wire cutters. Cut them once they have been soldered in place. Any stray pieces of metal may connect with other components causing a short circuit.
- When making holes for the LED and switches in the cover you may want to use a hole punch, or push a pencil through into some modelling clay.

Advice on soldering:

- Give Scouts only as much solder as they need for the project. The temptation to see what happens when a soldering iron is held against a whole reel of solder can be hard to resist!
 - Lead-free solder can leave a residue on the tip of the soldering iron and stop it from working properly. This should be cleaned using a soldering iron tip cleaner.
- Never** clean soldering irons with an abrasive as this will remove their coating.

Meeting the aims of the badge:

- Introduces digital electronics and the use of digital outputs in a circuit.
- Introduces integrated circuits and microprocessors.
- Develops soldering skills.



PROJECTS 08 - ELECTRONIC DICE 1/2



Difficulty: Intermediate

Time needed: 1 - 2hrs (1hr to build the circuit and 1hr to design a cover for the dice)

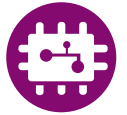

This project uses a kit to create an electronic dice that randomly generates a number between one and six at the press of a button.

The project uses a printed circuit board and is made up of seven LEDs that are connected to a pre programmed microcontroller on an integrated circuit (IC). The microcontroller is in effect a small computer and is programmed to rapidly cycle through numbers 1 to 6 when the button is pressed. When the button is released a final number is displayed and the IC determines which of the LEDs should be lit up.



The Scouts will need to solder the circuit to ensure that the connections are secure. If any of the components come loose the circuit will be broken and the dice will not work.



Once they have built the circuit, they can design a cover for the dice ensuring that there are holes for the LEDs and button. The Scouts will have to carefully measure the spacing of the holes to ensure that the LEDs and button line up.



Preparation:

Electronic parts	Kitronik code	Indicative cost (2012)
1x Electronic dice kit	2109	£3.78
2x AA battery pack of two	2201-01	£1.10

Other consumables

Solder

Card or thin foam board (optional)

Pens, pencils or crayons (optional)

Tools and equipment

Soldering iron

Wire cutters

Scissors (optional)

Single hole punch or craft knife (optional)

PROJECTS 08 - ELECTRONIC DICE 2/2

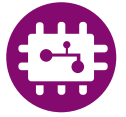

Advice on soldering:

- Give Scouts only as much solder as they need for the project. The temptation to see what happens when a soldering iron is held against a whole reel of solder can be hard to resist!
- Lead-free solder can leave a residue on the tip of the soldering iron that stops it from working properly. This should be cleaned using a soldering iron tip cleaner.
Never clean soldering irons with an abrasive as this will remove their coating.

Hints and trouble-shooting:

- The kit comes with instructions on how to construct the dice and tips on what to do if it does not work.
- It can be quite fiddly to put together as the parts are small, Scouts will need good lighting and clear work spaces.
- Some of the components will need to be trimmed with wire cutters. Cut them once they have been soldered in place. Any stray pieces of metal may connect with other components causing a short circuit.
- When making holes for the LED and switches in the cover you may want to use a hole punch, or push a pencil through in to some modelling clay.

Meeting the aims of the badge:

- Introduces digital electronics and the use of digital outputs in a circuit.
 - Introduces integrated circuits and microprocessors.
 - Develops soldering skills.
-

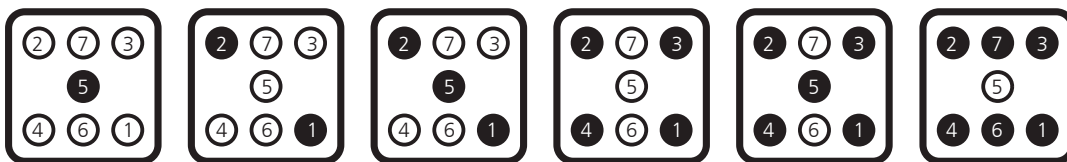

PROJECTS 09 - GUY ROPE GUIDES 1/3

Difficulty: Difficult

Time needed: 1 - 2hrs

This project uses strip board to create a flashing LED light that can be attached to guy ropes so that Scouts don't trip over them in the dark. The project uses a integrated circuit chip called a 555 chip. These are readily available and used in a wide range of appliances.

The pins of a 555 chip have different functions. For this project the 555 chip is used to produce a 'square wave'. As the capacitor charges and discharges the 555 chip changes the voltage to the LED from high to low, causing it to flash on and off.

The Scouts will need to solder the circuit to ensure that the connections are secure. If any of the components come loose then the circuit will be broken and the game will not work.

Although this project uses strip-board and can be more difficult to complete than the electronic game or dice, Scouts may find it easier to grasp the concept of digital electronics through constructing it.

Once they have built their flashing LED they will need to find some way of protecting it from the elements and attach it to the guy ropes. An easy way to do this is to put it in to a clear sandwich bag and tie this to the guy ropes with string.

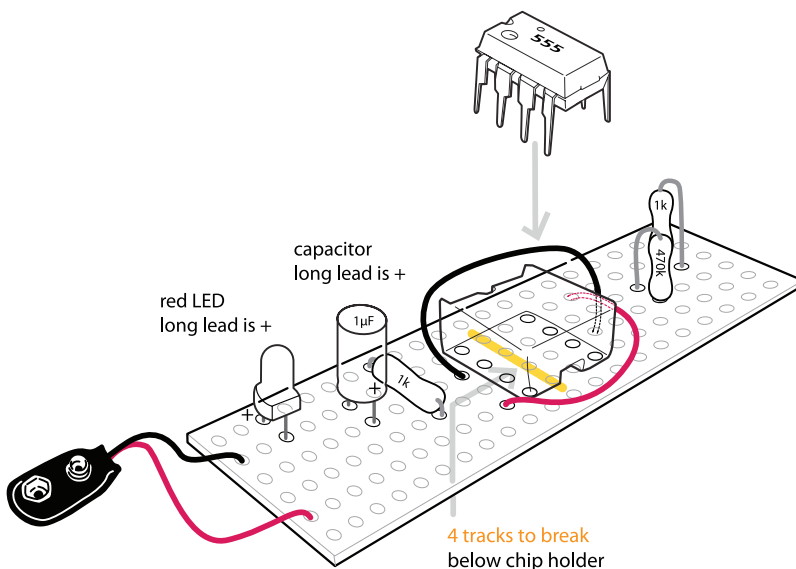
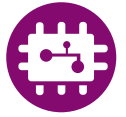

PROJECTS 09 - GUY ROPE GUIDES 2/3



Preparation:

Electronic parts	Maplin code	Kitronik code	Indicative cost (2012)
1 x resistor 470k	M470K	3003-470K	29p
2 x resistor 1k	M1K	3003-1K	50p
1 x capacitor 1 μ F	VH16 or VH17	3102-1U	49p
NE555N chip	QH66	2908	89p
IC holder	BL17	2930	39p
Strip-board (can be cut and used for 4 projects)	N99CF	2439	£3.99
9V battery	N82KU	2211-01	£3.99
Battery snap	HF28	2238-01	£1.19
Wire			



Other consumables

Solder

Plastic sandwich bags (optional)

String (optional)

Tools and equipment

Soldering iron

Wire cutters

Spot face cutter or drill bit

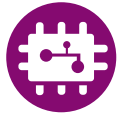

Advice on soldering:

- Give Scouts only as much solder as they need for the project. The temptation to see what happens when a soldering iron is held against a whole reel of solder can be hard to resist!
- Lead-free solder can leave a residue on the tip of the soldering iron and stop it from working properly. This should be cleaned using a soldering iron tip cleaner.
Never clean soldering irons with an abrasive as this will remove their coating.

Hints and trouble-shooting

- This project can be quite fiddly to put together as the parts are small, Scouts will need good lighting and clear work spaces.
- You will need to strip back some pieces of wire and solder into place to make connections between some of the IC pins. Make sure you leave enough exposed wire to solder in place.
- Some of the components (resistors and LEDs) will need to be trimmed with wire cutters. Cut them once they have been soldered in place. Any stray pieces of metal may connect with other components causing a short circuit.
- You will need to break the tracks of the strip board under the IC once it has been soldered. You can do this with a spot face cutter or drill bit by placing it into a hole on the back of the board and twisting until it breaks the metal tracks.
- Care should be taken to ensure that solder doesn't flow across different strips of the strip board.
- Check for any dry joints where the solder hasn't made a good connection. You may need to remove solder with a desoldering pump and try again.

Meeting the aims of the badge:

- Introduces digital electronics and the concept of converting analogue signals into digital outputs.
 - Introduces integrated circuits and microprocessors.
 - Reinforces understanding of the role of capacitors.
 - Develops soldering skills.
-

CHALLENGES

Here are some more open ended challenges that you can give Scouts if they are really interested and want to do more. All challenges include Scouts resources to accompany them and are designed to be a fun addition to the requirements of the badge.

CHALLENGES 01 - MAKE A CREDIT CARD TORCH

Difficulty rating: Easy

A credit card torch is simply a lithium coin battery sandwiched between two pieces of card with super bright LED wires on either side of the battery. The torch is sprung so that only when the sides are squeezed together do the wires of the LED touch either side of the battery lighting up the LED. When you let go, the circuit is broken and the light goes out.

This open ended challenge gives some of the information and kit needed in the Scouts resources, but it does not go in to how to create the spring. You can achieve this in any way you like, a small piece of foam, or a paperclip bent back on itself might be suitable, although you have to be careful not to create a short circuit by the paperclip touching the battery.

CHALLENGES 02 - MAKE A MARSHMALLOW TOASTING ALARM

Difficulty rating: Intermediate

This challenge uses a tilt switch to sound an alarm when the circuit is tilted at a certain angle. A tilt switch contains a substance, often mercury, which when tipped to one side makes a connection across the switch completing the circuit and sounding the alarm. This is an easy circuit to construct and could be put together with tape. The more difficult aspect is working out how to control the switch and mount the circuit so that the angle is controlled.

CHALLENGES 03 - MAKE A FLASHING BADGE

Difficulty rating: Difficult

This challenge builds on the skills and knowledge Scouts have gained in using digital electronics to construct a flashing Electronics Activity badge. They can make a copy of the badge logo and cut out the 'sparks' at the top of the mast and place a flashing LED behind it so that it looks like it is flashing on and off. The flashing LED project outlined in this pack uses a 9V battery, so they would also have to think about how to construct a pocket for the battery.



"The five essential skills for success are concentration, discrimination, organisation, innovation and communication".

Michael Faraday.